

## WiLink™ 4.0 single-chip mobile WLAN solutions



### Key features:

- Complete WLAN hardware and software solutions optimized for mobile IEEE 802.11b/g, IEEE 802.11a/b/g applications
- Single-chip 802.11 Media Access Controller/Baseband/RF transceiver WLAN solutions (TNETW1251 and TNETW1253) reduce BOM costs, save PCB space and extend standby and talk times
- Voice over WLAN (VoWLAN)-ready: Sophisticated power-saving sleep modes match the packet and traffic characteristics of VoWLAN applications
- First WLAN solutions using 90 nm manufacturing process and uses TI's Digital RF Processor (DRP™) technology to enable market leading physical size (6 mm x 6 mm BGA) and low power consumption
- Industry's lowest power consumption with TI's ELP™ technology extends battery life of handsets, wireless PDAs and other mobile devices
- *Bluetooth*® coexistence technology ensures high quality of service during simultaneous voice and data WLAN and *Bluetooth* operations

## P R O D U C T B U L L E T I N

### Overview

Texas Instruments' (TI's) WiLink™ 4.0 mobile WLAN platform is a complete hardware and software offering optimized for mobile phones. TI's WiLink 4.0 platform offers two different hardware single-chip implementations to provide flexibility for OEMs to offer IEEE 802.11b/g or IEEE 802.11a/b/g operation. The TNETW1251 WiLink 4.0 802.11b/g solution and the TNETW1253 WiLink 4.0 802.11a/b/g solution are single chips which integrate the media access controller (MAC), baseband processor and RF transceiver. Additionally, both single chips support IEEE 802.11e/i/d/k and the TNETW1253 WiLink 4.0 802.11a/b/g solution also supports IEEE 802.11h/j.

The TNETW1251 and TNETW1253 WiLink 4.0 single-chip solutions are manufactured in 90 nm process technology and make extend TI's leadership in single-chip integrated solutions using TI's Digital RF Processor (DRP™) technology. Both single-chip solutions are pin-for-pin compatible to simplify manufacturers' product line strategies for 802.11b/g and 802.11a/b/g products. This compatibility enables just-in-time manufacturing options that are responsive to marketplace demand and design reuse to speed time-to-market of new products.

The WiLink Software Development Kit (SDK) 4.X included with the WiLink 4.0 platform is optimized for embedded applications. This includes support for Linux®, Windows® WinCE™, Symbian™ operating systems, as well as lab testing and manufacturing software. It is also partitioned to minimize host CPU loading and power consumption in mobile applications.

## WiLink 4.0 solutions

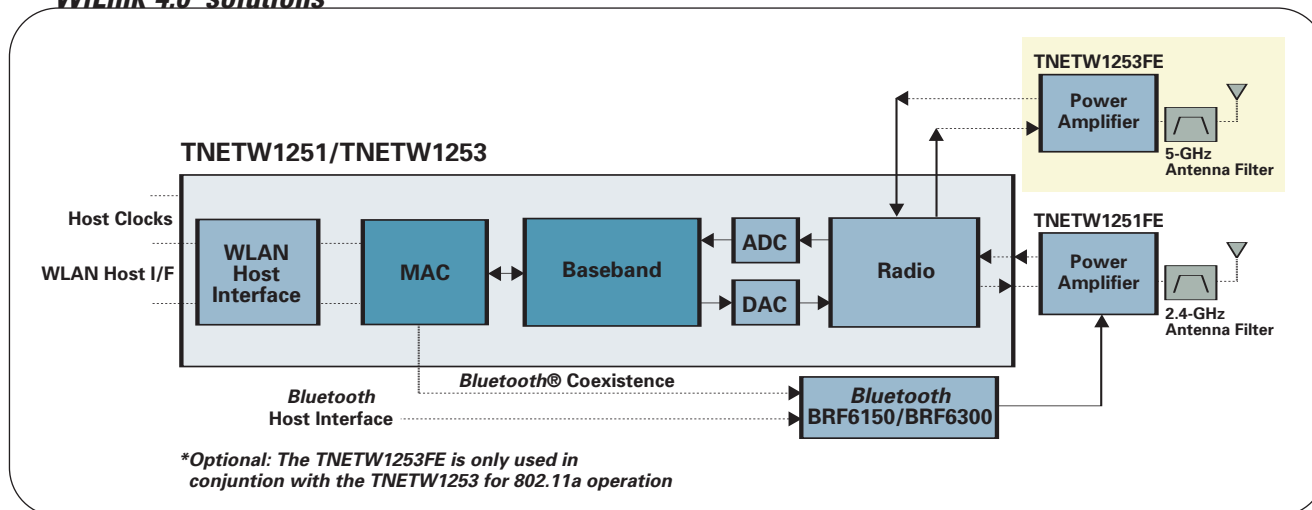

The WiLink 4.0 platform also includes support for Voice over WLAN (VoWLAN) applications which are driving WLAN adoption in mobile devices. As single-chip solutions with low cost, power and small size, the TNETW1251 and TNETW1253 WiLink 4.0 solutions are driving VoWLAN access into consumer cell phones. WiLink 4.0 solutions are VoWLAN-ready with support of:

- UMA (Unlicensed Mobile Access) technology
- VoIP over WLAN
- Quality of service, WPA, WPA2, CCX2.0, 3.0 and 4.0 for application specific devices
- Advanced roaming support enabling rapid migration between access points and between WLAN and cellular subsystems

The WiLink 4.0 mobile WLAN solutions have been optimized for low-power, battery-driven mobile wireless communications. As such, they support extended talk time as well as longer standby times by using TI's ELP™ technology for low power standby modes and other advanced technology to deliver maximum battery life.

Designed for interoperability and coexistence, the WiLink 4.0 mobile WLAN single-chip solutions are capable of cost-efficient collaboration and effective coexistence with short-range *Bluetooth* personal area networking (PAN). For instance, WLAN and *Bluetooth* technologies are able to share the same antenna and antenna filter, reducing bill of materials (BOM) costs and circuit board space. In addition, TI's WLAN/*Bluetooth* coexistence technology ensures effective simultaneous operations of voice and data.

[www.ti.com/wireless](http://www.ti.com/wireless)

**Important Notice:** The products and services of Texas Instruments Incorporated and its subsidiaries described herein are sold subject to TI's standard terms and conditions of sale. Customers are advised to obtain the most current and complete information about TI products and services before placing orders. TI assumes no liability for applications assistance, customer's applications or product designs, software performance, or infringement of patents. The publication of information regarding any other company's products or services does not constitute TI's approval, warranty or endorsement thereof.

Technology for Innovators, the black/red banner, WiLink, ELP and DRP are trademarks of Texas Instruments. The Bluetooth word mark and logos are owned by the Bluetooth SIG, Inc., and any use of such marks by Texas Instruments is under license. All other trademarks are the property of their respective owners.

B011905